



Graco® Supply Systems

Sealant & Adhesive Supply Systems with NXT™ Technology



The Next Generation of Bulk Supply Systems with NXT Technology

- Dispenses sealants, adhesives and other medium to high-viscosity materials
- Tested to perform and last as long as possible
- NXT Air Motor and Check-Mate® technologies set the industry standard for long-lasting durability
- Intuitive, easy-to-use, advanced pneumatic and electronic controls
- Provides material tracking, runaway control, electric crossover and more

PROVEN QUALITY. LEADING TECHNOLOGY.

Graco Supply Systems with NXT Technology

Discover the next generation of technology and performance

Graco Supply Systems can help maximize your plant's production capacity with innovative features, and new pump and air motor technologies. Its modular design simplifies maintenance, and its new technology improves process control.

Easy to Service

- Smart design and simple features reduce time spent on maintenance
- A lift ring raises the air motor for easy maintenance

NXT Air Motor

The next generation of Graco air motors

- Long-lasting and durable
- Easy to repair
- Modular air valve eliminates stalling

MaxLife® Check-Mate® Pump

Modular design makes cartridge packings easy to replace

Integrated Drum Air Blow-Off

Reduces downtime with quick, easy drum changes

Integrated Air Controls

- Conveniently located — easy to see, easy to use

Tandem Control

Provides automatic crossover and advanced features for improved process efficiency and control

DataTrak™ Control

- Tracks material usage and flow
- Provides pump runaway protection
- Supports preventative maintenance strategies



Platen Design

- Minimizes leftover material and reduces waste
- Easy drum replacement keeps production moving
- Long-lasting, one-piece platen seals are easy to replace

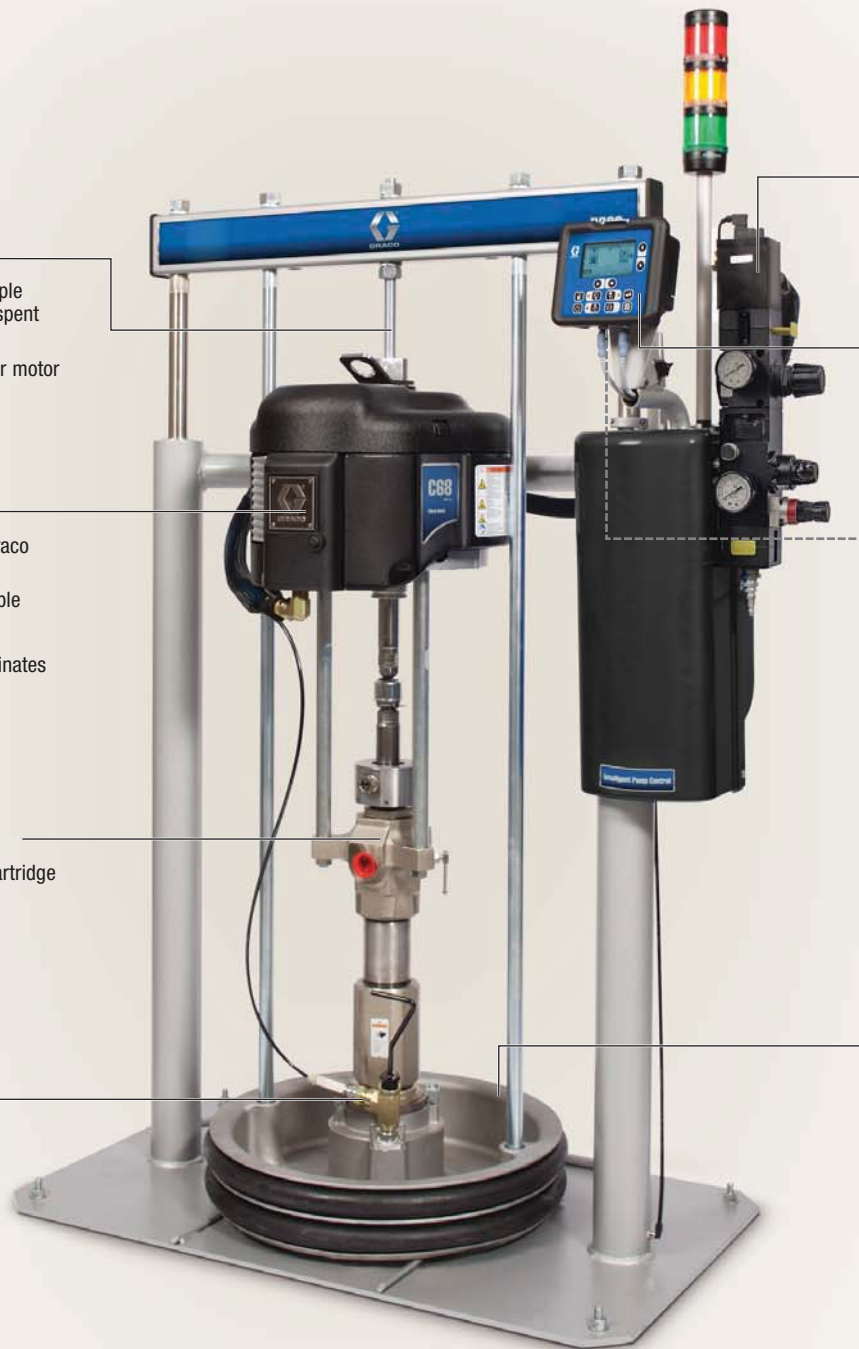

Graco D200 Supply System

Designed to Reduce Your Cost of Ownership



Graco Supply Systems have been thoughtfully designed with features that minimize maintenance and streamline normal everyday operations. In addition, Graco Supply Systems are built with high-quality parts for longer life and reliability.

Features that reduce your cost of ownership:

- Standard Severe Duty® coatings and seals are engineered to last very long
- Optional MaxLife coatings and seals double the life of the severe-duty coating
- NXT Air Motor is the new standard in air motor durability, lasting ten times longer than the King air motor
- Common and shared parts throughout rams and air motors provide low carrying costs, even when multiple configurations are used within a plant
- Optional enclosed wet cup protects seals from contamination and allows recirculation, significantly extending seal life
- Electric tandem systems significantly reduce downtime, thanks to advanced monitoring and control of critical factors, all provided through a simple, easy-to-use graphic interface

Features that make Graco Supply Systems easier to use:

- Drum stops and rails, plus optional roller, allow quick, easy, accurate placement of drum or pail
- Xtreme® quick-disconnect coupler, lift ring mount, and pump cartridge packings let you service the pump without removing the pump from the ram
- One-piece platen wipers last longer than ever before and can be replaced in seconds
- Integrated air controls offer easy-to-see, easy-to-use control in one location
- Intuitive electronic user interfaces give the operator immediate and important information at the touch of a button
- Optional low/empty sensors and light tower lets the operator know the status from a distance, signaling when drum changes are needed
- Optional electric tandem filter monitoring and electric depressurization allow complete control over the tandem system

Applications:

- Material transfer
- Packaging and re-packaging
- Window and door manufacturing
- High-volume feeding
- Automotive body shop and paint shop
- Manufactured housing

Materials:

- Urethanes
- Epoxies
- Acrylics
- Silicones
- Lubricants
- Lithographic inks
- Polysulfides
- Specialty resins
- Autobody sealer
- PVC
- Butyl
- Latex

Reliable. Easy to Use. Easy to Service.

NXT Air Motor – the next generation of Graco air motors

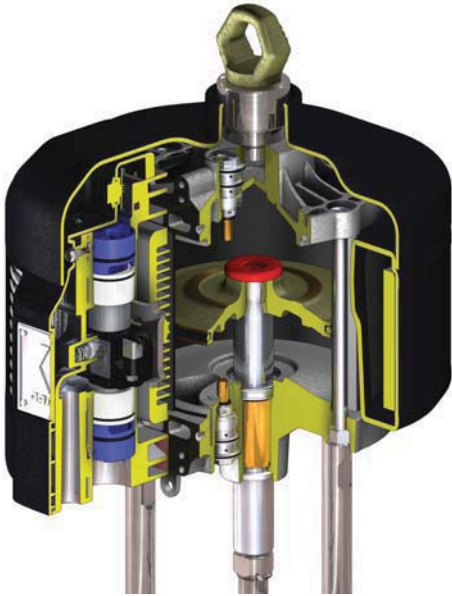

Reduced Icing and Noise

Patented exhaust manifold reduces noise and icing — up to 50% quieter than previous models

Rugged Polymer Body Armor

Won't rust or dent

Modular Design

For easier maintenance

Check-Mate Pump – a time-tested, proven performer

NEW Xtreme Coupler

Quick-disconnect coupler for easy maintenance

Replaceable Outlet Fitting

Reduces repair costs

Piston Valve with Floating Piston Seal

For maximum pressure balance over a range of material viscosities

Replaceable Seat

Minimizes service costs

Floating Priming Plate

Provides uniform flow

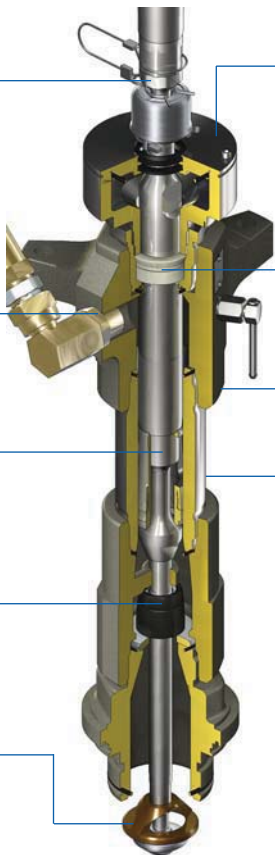

NEW Optional Enclosed Wet Cup

- Prevents seal contamination and allows recirculation
- Reduces maintenance and extends seal life

NEW Cartridge Throat Packings

Allows for easy servicing without removing from ram

Cast Outlet and Inlet Housing

Improves structural integrity

Hard Part Coatings

- Standard Severe Duty coating on rods and cylinder maximizes wear life
- NEW optional MaxLife coating doubles pump life over standard offering

NXT Technology: Less pulsation for better results

NXT Air Motor technology provides a smooth, rapid changeover for a more consistent bead and less downtime.

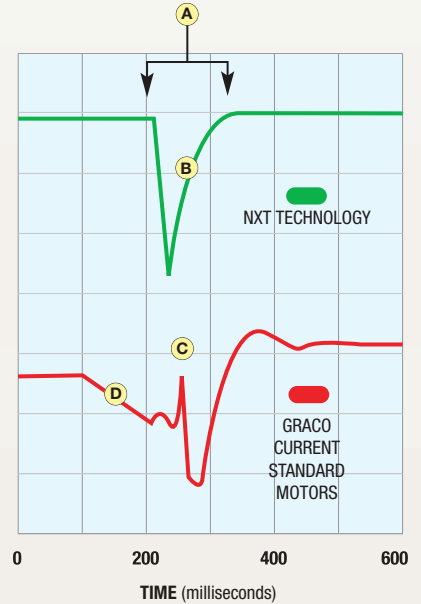

A Less than $\frac{1}{15}$ of a second changeover!

B Quick changeover and recovery with less pulsation

C Pressure spike at changeover

D Longer changeover causing pulsation

Noise-reduction technology

The quiet, low-noise NXT Air Motor operates around 87 decibels, while other comparable motors operate up to 103 dB(A).

